

NOTE:
 STEEL PLATE INSERT SHOULD BE SIZED AS REQUIRED FOR TIE-DOWN ANCHOR W/ 6' X 6" MINIMUM PLATE DIMENSION TO APPLICATION OF ALT THIXO FLASHING.

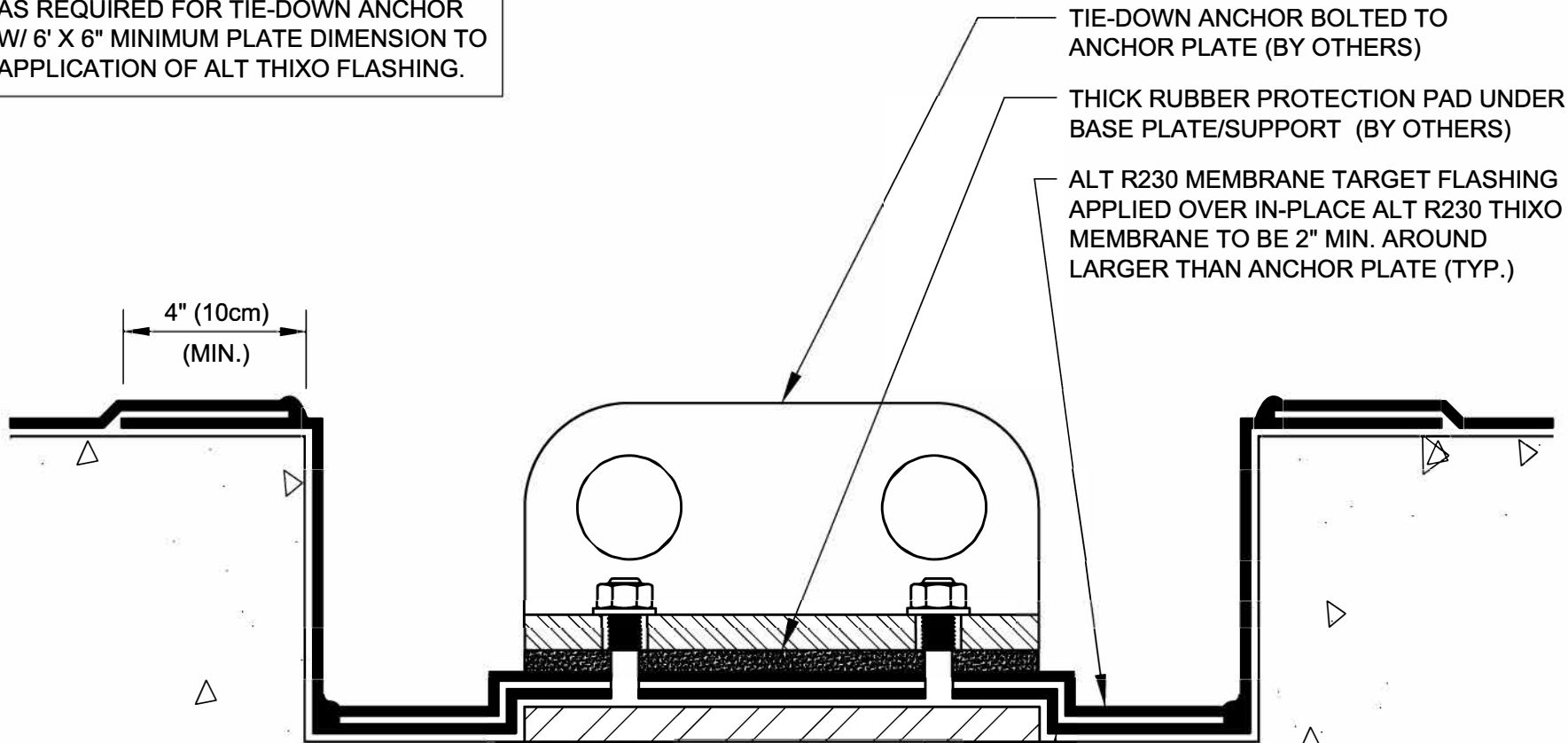

TIE-DOWN ANCHOR BOLTED TO ANCHOR PLATE (BY OTHERS)

THICK RUBBER PROTECTION PAD UNDER BASE PLATE/SUPPORT (BY OTHERS)

ALT R230 MEMBRANE TARGET FLASHING APPLIED OVER IN-PLACE ALT R230 THIXO MEMBRANE TO BE 2" MIN. AROUND LARGER THAN ANCHOR PLATE (TYP.)

4" (10cm)
 (MIN.)

DEGREASE PLATE & ANCHORS W/ ALT ACTIVATOR PRIOR TO APPLYING ALT METAL PRIMER (TYP.)

PREPARE, LEVEL & PATCH SUBSTRATE W/ALT R290 PASTE OR ALT RS242 MORTAR AFTER PRIMING & PRIOR TO APPLICATION OF ALT R230 MEMBRANE (TYP.)

ALT R230 THIXO FLASHING APPLIED TO PREPARED & PRIMED SUBSTRATE

STAINLESS STEEL INSERT PLATE W/ 316 S.S. WELDED THREADED STUDS ANCHORED OR SET INTO CONCRETE (BY OTHERS)

DRAWING NO.:

M-2K

AM_02K

**RAILING SUPPORT MOUNTING PLATE FLASHING
 (TOP DOWN VIEW)**

REVISION	0	ISSUE DATE	10-15-2014	SCALE	N.T.S.	DRAWN BY	ALT Global
----------	---	------------	------------	-------	--------	----------	------------

